

S y s t e m



CHOICE

f f i c e



B a s i c

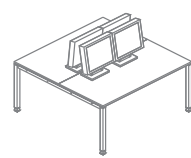
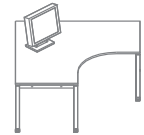
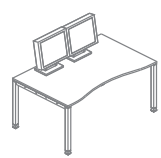

leuWico

CHOICE



E i n f a c h g u t .

Mehr denn je wird von Büroarbeitsplätzen erwartet, dass sie sich leicht und stilvoll an jede Umgebung anpassen. Die neue Einfachheit darf keine Abstriche bei der Professionalität bedeuten.

CHOICE setzt hier Maßstäbe:

Eine hohe Gestaltungs- und Materialqualität sowie eine umfangreiche Auswahl an Plattenformen und -größen machen CHOICE zu einem zeitgemäßen und zukunftsorientierten Einrichtungssystem.

Elegante Fußgestelle, edle Oberflächen, eine unkomplizierte Höheneinstellung, intelligente Kabelführung und die Anbindung von funktionserweiternden Bauteilen zeichnen das System aus.

CHOICE ist eine der schönsten Antworten auf eine Büro- und Arbeitswelt im Wandel. In Form und Funktion eine gute Wahl.



S i m p l y g o o d .

More than ever office work stations have to adapt easily and stylishly to every type of environment. However, the new simplicity may not reduce professionalism. CHOICE sets new benchmarks on this sector:

A high arrangement and material quality as well as a wide selection of worktop shapes and dimensions turn CHOICE into a modern and future-oriented furnishing system. Smartly shaped desk frames, precious surfaces, an uncomplicated height adjustment, a well thought-out cable management and the connection of expanding components characterise this system.

CHOICE is one of the nicest answers to a changing office world. First class form and function.

CHOICE



4



5



CHOICE



CHOICE



CHOICE



10

11

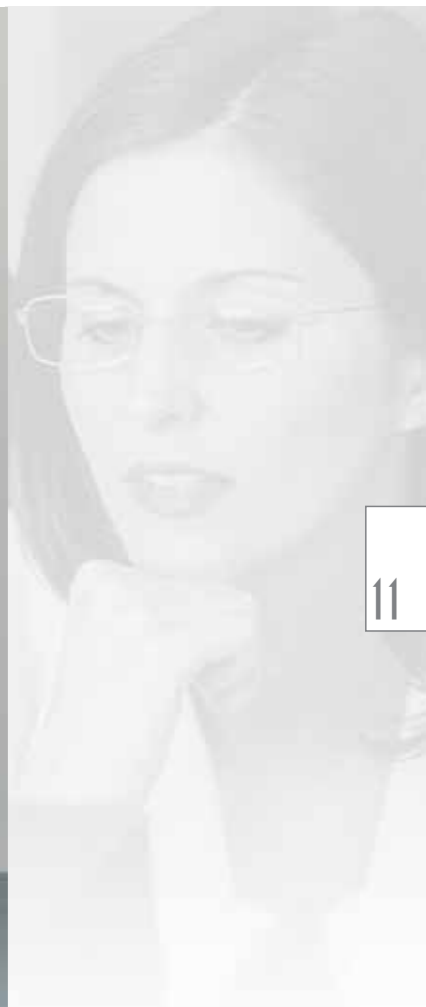

CHOICE



CHOICE

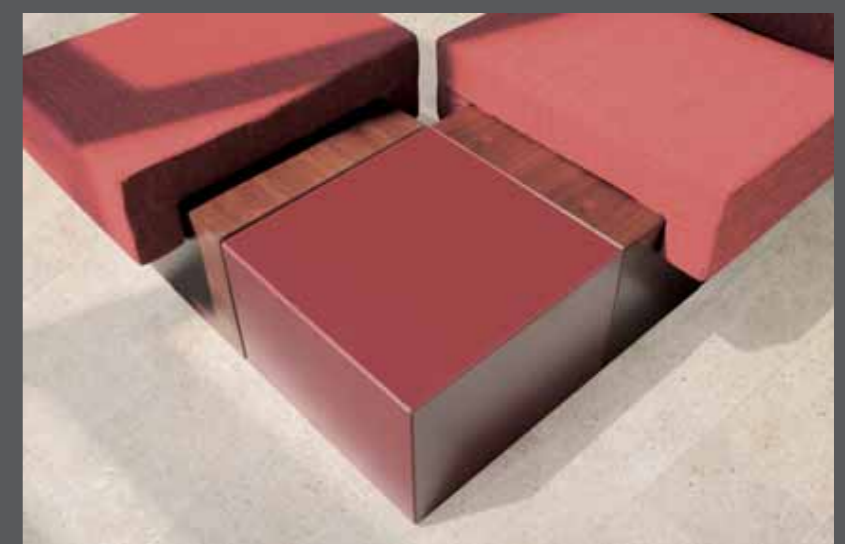

CHOICE



16



17



CHOICE









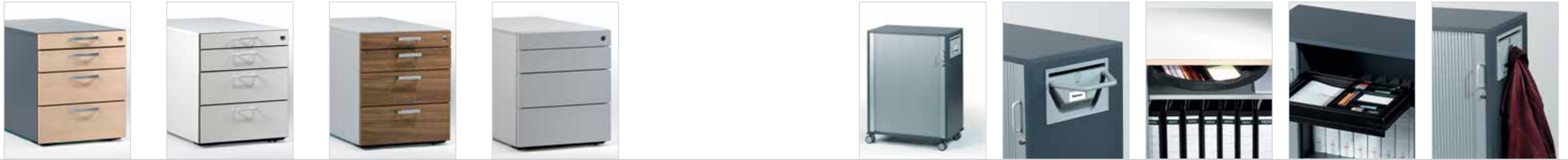

20

21

CHOICE



-  **Standard**
Griff Form A
handle type A
-  **-GB**
Griff Form B
handle type B
-  **-GG**
Griff Form G
handle type G
-  **-GH**
Griff Form H
handle type H
-  **-GI**
Griff Form I
handle type I
-  **-GJ**
Griff Form J
handle type J
-  **-GM**
Griff Form M
handle type M
-  **-GK**
Griff Form K
handle type K

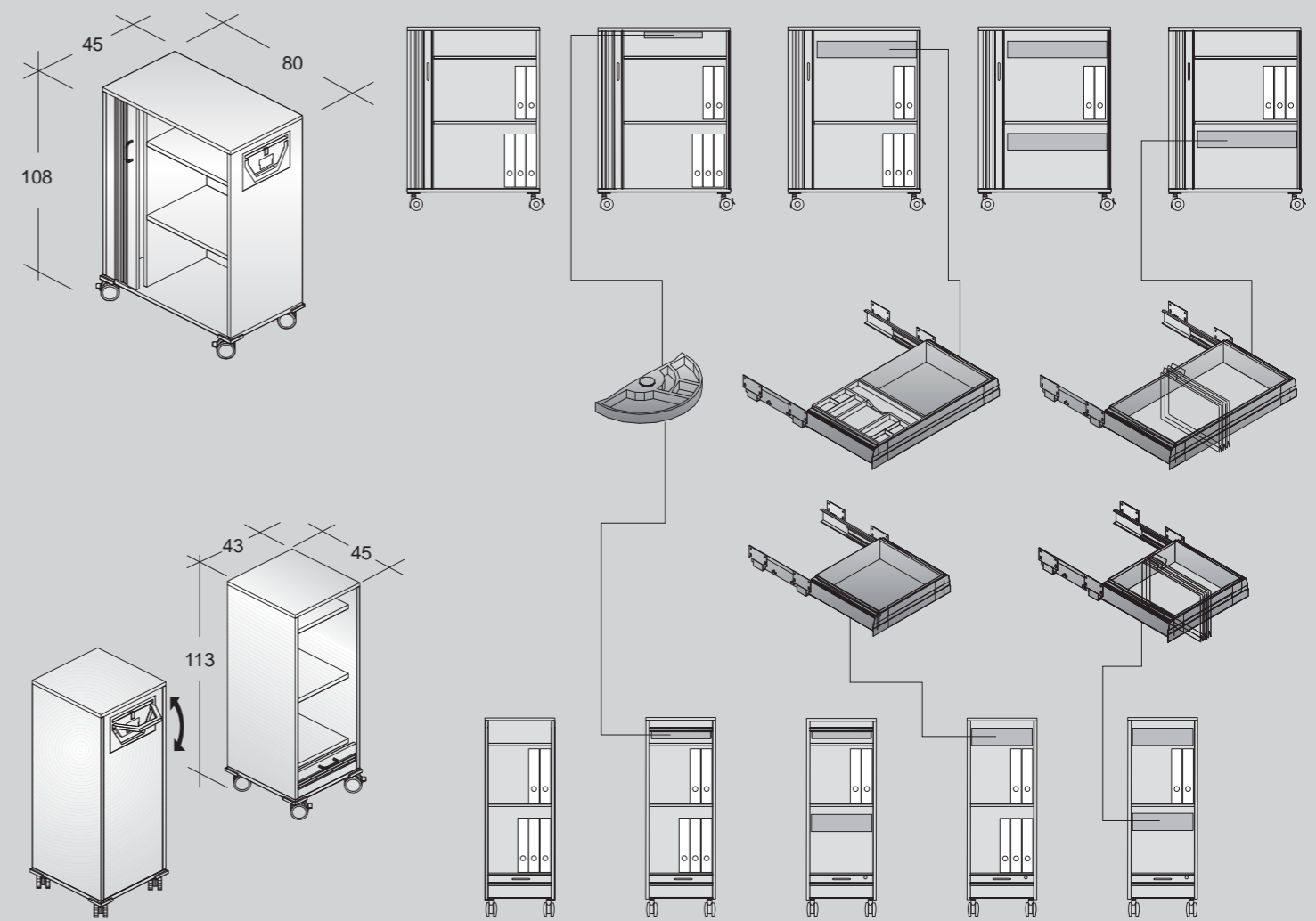
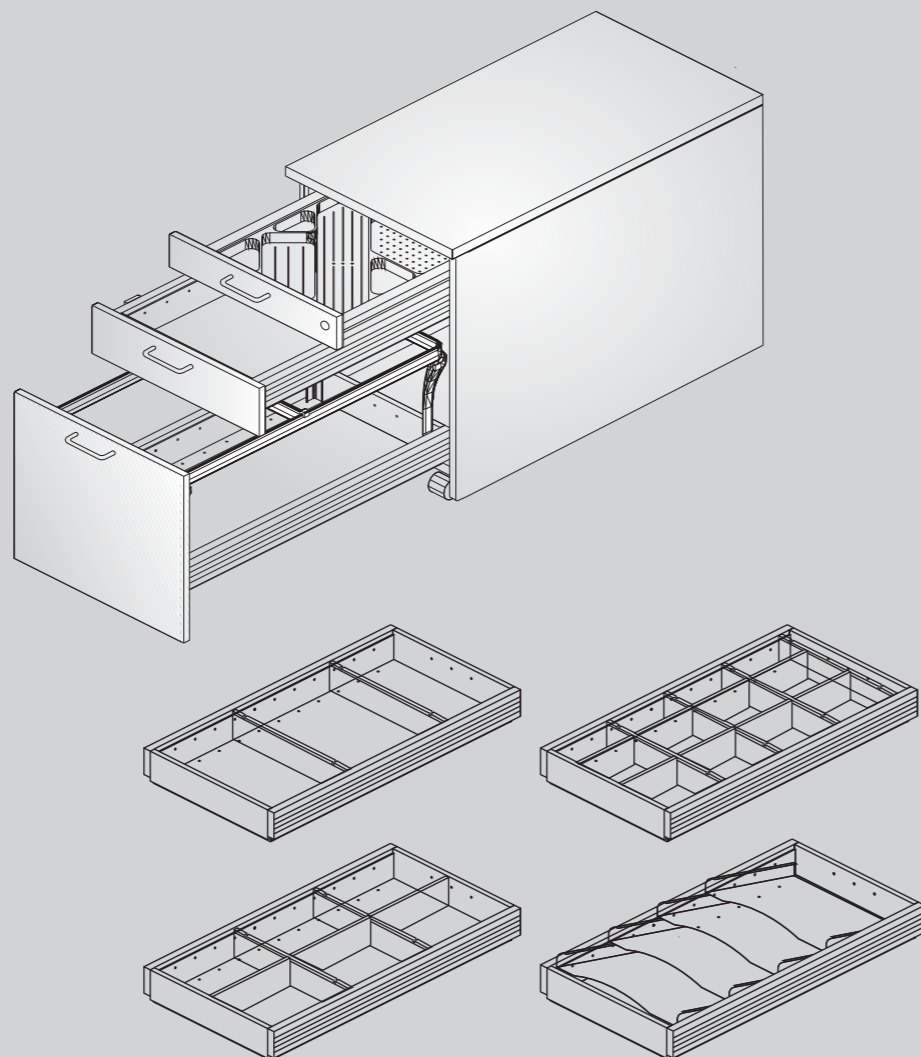

22

23



Anmerkung:
Dieses Farb- und Materialmusterblatt wurde mit denkbar größter Sorgfalt erstellt. Trotzdem kann es im Druck zu Abweichungen kommen. Lassen Sie sich im Zweifelsfall die Originalmuster zeigen.



Please note:
We took a lot of care over this list with colours and materials. However there could be differences in printing. In case of doubt, please ask for samples.



Akustik

Die Gestaltung der akustischen Verhältnisse in Büroräumen wird heute als wichtiger Punkt einer modernen, ergonomischen Einrichtung verstanden. Lärm senkt die Effektivität – egal ob er von Geräten oder Kollegen verursacht wird.

Der Direktschall und die Gesamtraumakustik müssen durch intelligente Büroeinrichtungslösungen positiv beeinflusst werden.

Gegenmaßnahmen oder besser ein Bürokonzept, das Belästigungen durch Lärm von vornherein vermeidet, sind also eindeutig auch ein Gebot der Wirtschaftlichkeit.

Acoustics

The acoustic conditions in offices are to be regarded as an important point of a modern, ergonomic furnishing today. Noise decreases effectiveness – no matter whether caused by machines or colleagues.

The direct sound and the total room acoustics have to be influenced affirmatively by intelligent office furnishing solutions.

Counter measures or even better an office concept which avoids noise pollution are definitely also a bid of economic efficiency.



schallabsorbierende Raumgliederungssysteme Sound absorbing screen system



schallabsorbierende Deckensysteme Sound absorbing ceiling systems



akustisch wirksame Bodenbeläge Acoustically effective floor covering



Rolläden mit Schallabsorbteigenschaften Roller blinds with sound absorbing features

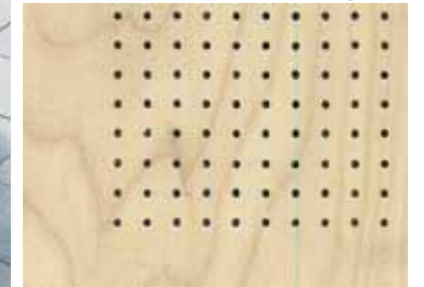

mikroperforierte Akustikfronten Micro-perforated acoustic fronts

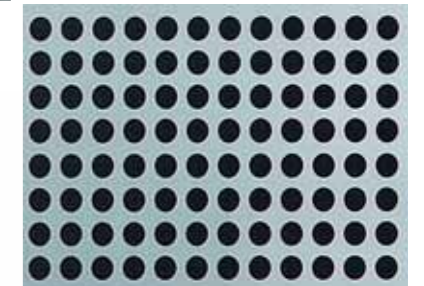

schalldämpfende Wand- und Deckenabsorber Sound absorbing wall and ceiling panels



stoffbezogener Schrankrückwandabsorber Fabric covered cupboard rear panel absorbers



mobiles schallabsorbierendes Stellwandssystem Mobile sound absorbing screens

CHOICE

Das richtige Licht

Ein wichtiges ergonomisches Kriterium: Das Beleuchtungsniveau muss der Sehaufgabe und dem Sehvermögen angepasst werden. Die Grundlage für optimales Licht ist ein ausgewogenes, regulierbares Verhältnis zwischen allgemeiner Grundbeleuchtung und individuell steuerbaren Lichtverhältnissen am Arbeitsplatz. Das betrifft gleichermaßen die künstlichen und natürlichen Lichtverhältnisse, also Beleuchtung und Beschattung.



The right light

An important ergonomic criteria is to create a lighting level that is perfectly adapted to the vision and work of the user. A balanced, controllable proportion of the general basic light and the individually adjustable light at the work place are the basis for optimal lighting conditions. This concerns the artificial as well as the natural lighting conditions like light and shade.



ER-10
Arbeitsplatzleuchte Desk Light



ER-20
Arbeitsplatzleuchte Desk Light



LU-10
Arbeitsplatzleuchte Desk Light



LU-20
Arbeitsplatzleuchte Desk Light



TU-10
Arbeitsplatzleuchte Desk Light



TU-20
Stehleuchte Floor Lamp



TU-30
Stehleuchte Floor Lamp



TU-40
Stehleuchte Floor Lamp



TU-50
Stehleuchte Floor Lamp



LU-30
Stehleuchte Floor Lamp



TU-60
Wandleuchte Wall Light



TU-70
Wandleuchte Wall Light



TU-80
Wandleuchte Wall Light



TU-90
Wandleuchte Wall Light



LU-40
Stehleuchte Floor Lamp



TU-100
Pendelleuchte Suspended Lamp



TU-110
Pendelleuchte Suspended Lamp



TU-120
Pendelleuchte Suspended Lamp



TU-130
Pendelleuchte Suspended Lamp



TU-140
Stehleuchte Floor Lamp

CHOICE



DA-10



DA-20



DA-30



DA-40



DA-50



DA-60



KL-10



KL-20



KL-30



KL-40



HA-10



HA-20



HA-30



HA-40



SA-10



DA-70



DA-80



DA-90



KL-50



KL-60

Der richtige Stuhl

Ein guter Stuhl unterstützt Sie in jeder Haltung und folgt bei jedem Bewegungsablauf. Er trägt zu einer wesentlichen Entlastung der Wirbelsäule bei.

Nutzen Sie die Bewegungsräume, die ein guter Stuhl bietet. Gerade bei der Bildschirmarbeit sind Haltungswechsel wichtig. Es gibt sie nicht, die ideale Dauersitzhaltung; die beste Sitzhaltung ist immer die nächste...

Die richtige Einstellung eines Stuhles entscheidet darüber, ob wir unserem Körper das bestmögliche Sitzenerlebnis geben oder ihn unnötig und zusätzlich belasten. Aber keine Sorge, alle hier empfohlenen Stühle zeichnen sich durch eine sehr komfortable Verstellmechanik aus.

The right chair

A good chair supports you, irrespective of your position whilst at the same time accompanying all of your movements. It contributes to a considerable relieving of the vertebral column.

Utilise the room for movement which a good chair offers. Position changes are especially important when carrying out VDU work. The ideal permanent sitting position does not exist. The best sitting position is always the next..

The correct positioning of your chair is responsible for deciding whether our body is provided with the best-possible seating experience or whether it is subjected to an unnecessary and additional burden. However, there is no need to worry, all these chairs are characterised by an extremely comfortable adjustment mechanism.

CHOICE



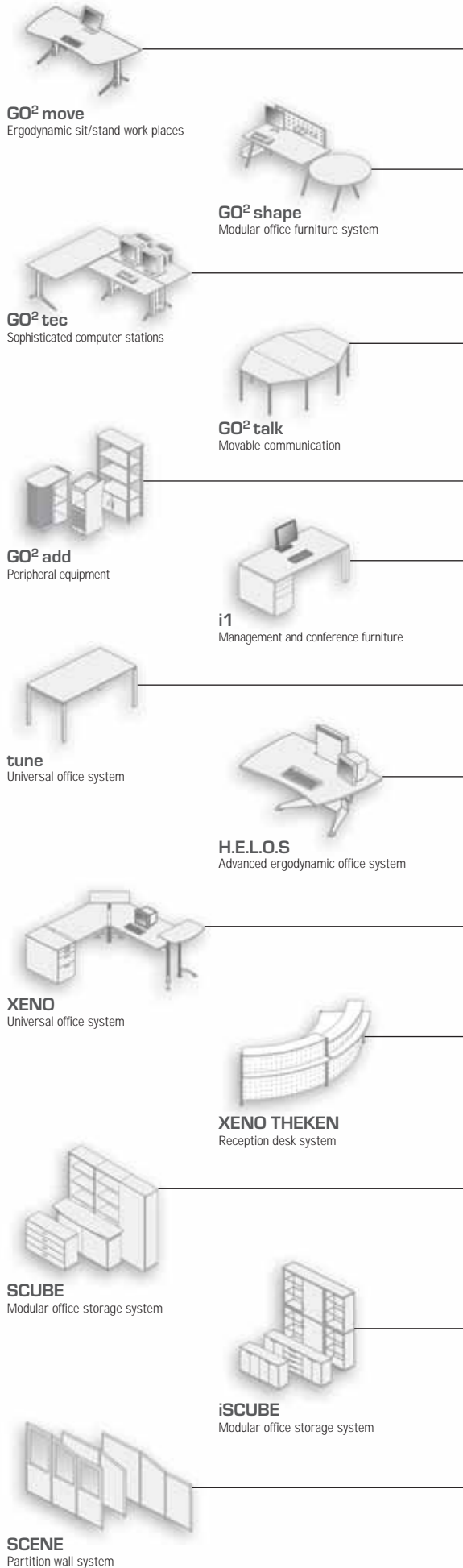

D LEUWICO GmbH & Co. KG

Entwicklung und Produktion
von Büro- und
Bildschirmarbeitsplätzen
D- 96484 Meeder-Wiesefeld
Tel. (09566) 880
Fax (09566) 88-114
Postfach 23 44
D- 96412 Coburg
email: info@leuwico.com
Internet: www.leuwico.com

A LEUWICO Austria GmbH

Büroeinrichtungen
Landwiedstr. 23
A- 4020 Linz
Tel. (0732) 67 17 93-0
Fax (0732) 67 43 57
email: office@leuwico.at
Internet: www.leuwico.at

NL LEUWICO Nederland B.V.

Rubberstraat 10
NL- 1411 AL Naarden
Tel. (035) 694 14 54
Fax (035) 694 16 42
email: info@leuwico.nl
Internet: www.leuwico.nl

CH JOMA-Trading AG

Weiernstrasse 22
CH- 8355 Aadorf
Tel. (052) 3654111
Fax (052) 3652051
email: info@joma.ch
Internet: www.joma.ch

UK DEALING ROOM CONSTRUCTION LTD.

2nd Mezzanine,
Becket House,
36 Old Jewry, London,
EC2R 8DD,
DDI: (020) 7776 8940
Fax: (020) 7776 0013
email: info@dealingrooms.co.uk
www.dealingrooms.co.uk

USA EISYS, INC.

112 28th Street South
Birmingham, AL 35233
Phone 205.941.1942
Fax 205.941.1781
email: info@eisis-inc.com
Internet: www.eisis-inc.com

