

CHOICE









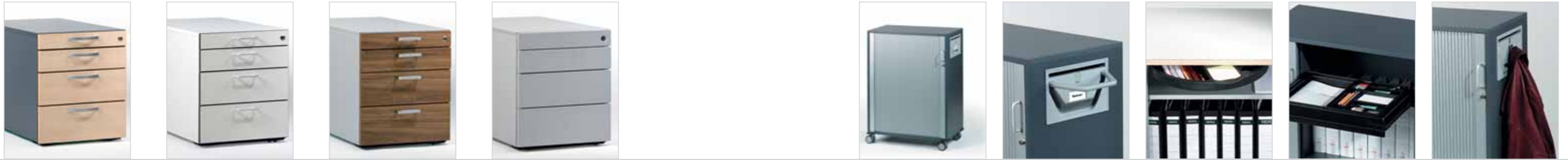

20

21

CHOICE



-  **Standard**
Griff Form A
handle type A
-  **-GB**
Griff Form B
handle type B
-  **-GG**
Griff Form G
handle type G
-  **-GH**
Griff Form H
handle type H
-  **-GI**
Griff Form I
handle type I
-  **-GJ**
Griff Form J
handle type J
-  **-GM**
Griff Form M
handle type M
-  **-GK**
Griff Form K
handle type K

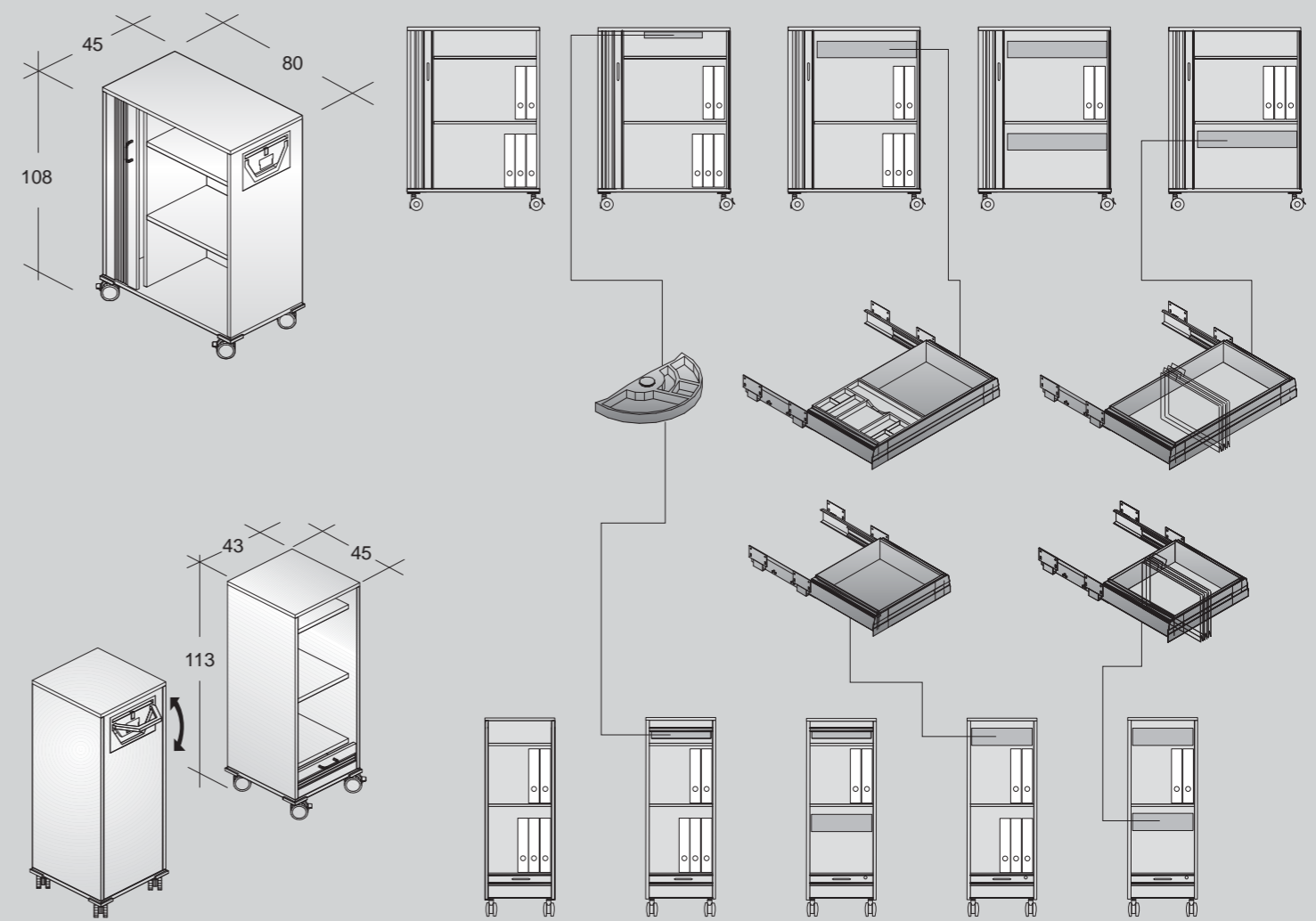
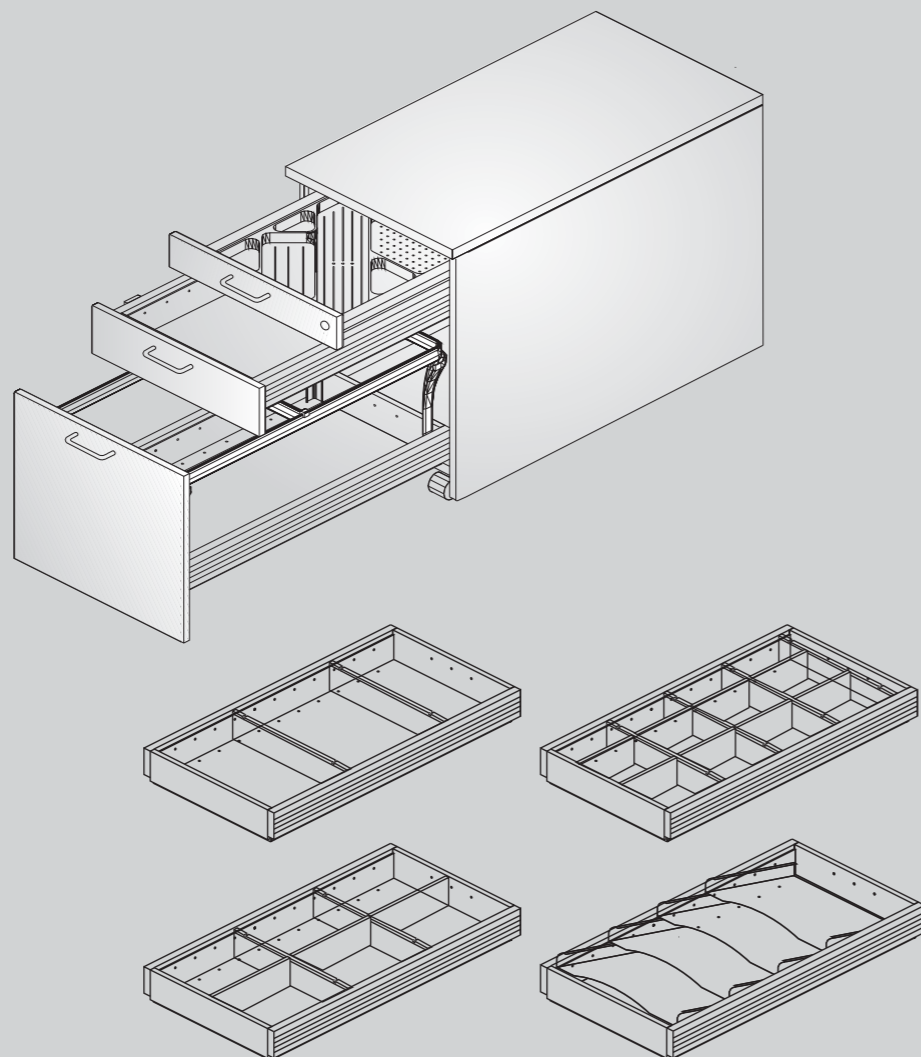

22

23



- kristallweiß
crystal white
- weißaluminium
aluminium white
- dunkelgrau
dark grey
- graphit
graphite
- lichtgrau
light grey



Anmerkung:
Dieses Farb- und Materialmusterblatt wurde mit denkbar größter Sorgfalt erstellt. Trotzdem kann es im Druck zu Abweichungen kommen. Lassen Sie sich im Zweifelsfall die Originalmuster zeigen.

- Ahorn
maple
- Weißbuche
light beech
- Buche
beech
- Birke
birch
- Eiche
oak
- Nussbaum
walnut



Please note:
We took a lot of care over this list with colours and materials. However there could be differences in printing. In case of doubt, please ask for samples.



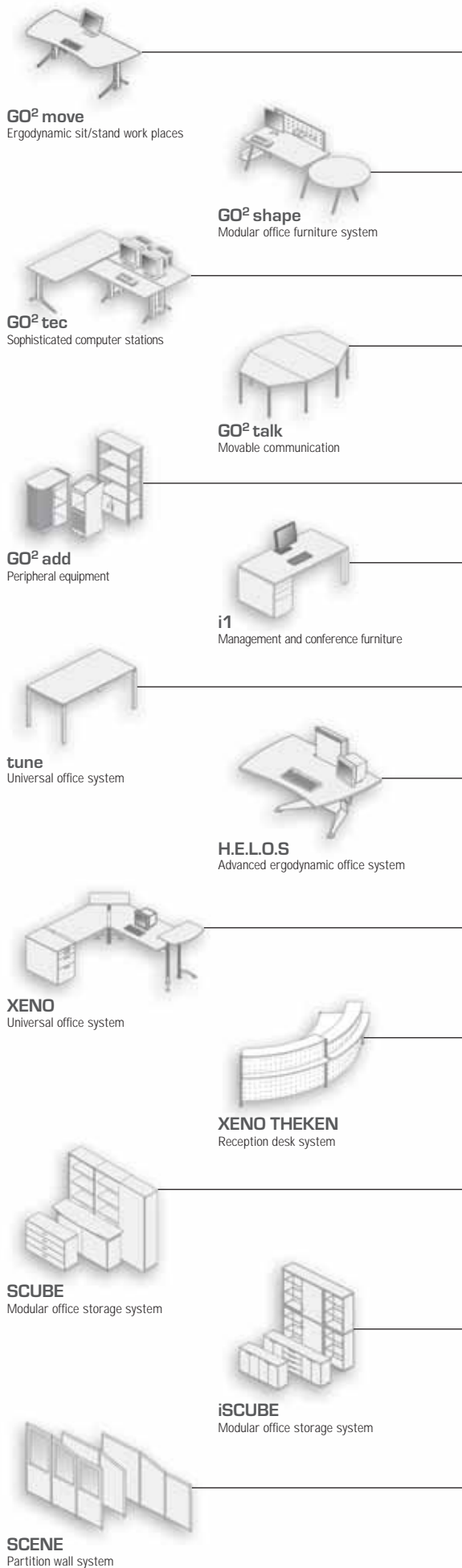

D LEUWICO GmbH & Co. KG

Entwicklung und Produktion
von Büro- und
Bildschirmarbeitsplätzen
D- 96484 Meeder-Wiesefeld
Tel. (09566) 880
Fax (09566) 88-114
Postfach 23 44
D- 96412 Coburg
email: info@leuwico.com
Internet: www.leuwico.com

A LEUWICO Austria GmbH

Büroeinrichtungen
Landwiedstr. 23
A- 4020 Linz
Tel. (0732) 67 17 93-0
Fax (0732) 67 43 57
email: office@leuwico.at
Internet: www.leuwico.at

NL LEUWICO Nederland B.V.

Rubberstraat 10
NL- 1411 AL Naarden
Tel. (035) 694 14 54
Fax (035) 694 16 42
email: info@leuwico.nl
Internet: www.leuwico.nl

CH JOMA-Trading AG

Weiernstrasse 22
CH- 8355 Aadorf
Tel. (052) 3654111
Fax (052) 3652051
email: info@joma.ch
Internet: www.joma.ch

UK DEALING ROOM CONSTRUCTION LTD.

2nd Mezzanine,
Becket House,
36 Old Jewry, London,
EC2R 8DD,
DDI: (020) 7776 8940
Fax: (020) 7776 0013
email: info@dealingrooms.co.uk
www.dealingrooms.co.uk

USA EISYS, INC.

112 28th Street South
Birmingham, AL 35233
Phone 205.941.1942
Fax 205.941.1781
email: info@eisis-inc.com
Internet: www.eisis-inc.com

